



MiniVisc 3000 Series

PORTABLE KINEMATIC VISCOMETERS

Solvent-free, simple to use, fast and accurate results

Applications include:

- **Machine Condition Monitoring –**
Increase availability of critical equipment by monitoring viscosity changes due to oil degradation and contamination. Avoid inadequate lubrication which causes adhesive wear in machinery and is a principal cause of equipment downtime.
- **Quality Control for Fuel/Oil Production and Blending**
- **Incoming Inspection Quality Control**

High accuracy 40C kinematic viscosity measurements for new and in-service oils

Lab-quality results when and where you need them

- Accuracy +/- 3% Relative Standard Deviation to NIST viscosity standards.

Solvent-free operation

- Fewer consumables, lower disposal costs and less environmental impact.
- Easy cleaning with the patented split-cell design – just wipe off the surfaces with a nonabrasive cleaning pad between samples.

Requires only a few drops of oil to test

- Obtain samples without impacting lubricant level; only a few drops (60 µL) of oil required. A positive displacement pipette is provided for the most precise, repeatable measurements.

Test even dark and sooty samples

- Innovative design allows testing of virtually any sample including dark and sooty or transparent samples without any pre-checks.

Portable, battery-powered design

- Fits easily into a toolbox or carrying bag and capable of operation for over six hours before recharge.

Expanded I/O capability

- Import sample lists and export measurement results via ViscTrack or AMS Oilview software.

ASTM compliance

- ASTM D8092 "Standard Test Method for Field Determination of Kinematic Viscosity Using a Microchannel Viscometer."

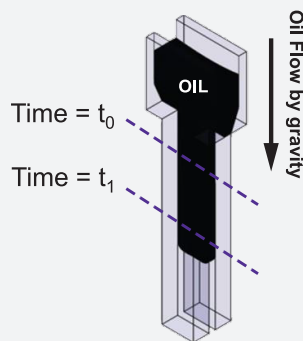

$$V_{40} = A * (t_1 - t_0) + B$$

*A and B are calibration coefficients



Principle of Operation

MiniVisc 3000 Series viscometers use a patented split cell design that enables measurement of kinematic viscosity using only a few drops (60 µl) of oil. When closed, the center pieces of the split cell form a funnel with a 100 micron gap allowing oil to flow down by gravity. Sensors along the funnel are triggered when oil flows by and flow time between two sensors is measured. The kinematic viscosity is then calculated. When opened, the split cell can be easily cleaned with a non-abrasive cleaning pad and it is ready for the next sample. The split cell is controlled at 40°C throughout the measurement.

MiniVisc 3000 Series Product Information

The MiniVisc 3000 includes the base viscometer, battery charger, USB cable, user's manual DVD and ViscTrack software. The recommended 3050 Standard Accessories Kit SA1021 includes a positive displacement pipette, disposable pipette tips and cleaning pads for 192 samples, and two viscosity standards kits.

The recommended 3000 Standard Accessories Kit SA1002 includes disposable 60 µl pipettes and cleaning pads for 100 samples, and two viscosity standards kits.

	MiniVisc 3000	MiniVisc 3050
Range	10-350 cSt	1-700 cSt
Outputs	V40	V40 V100 (calculated)
Pipette	Disposable pipette	Positive displacement pipette

PART NUMBER	
800-00138	MiniVisc 3050 Portable Viscometer, 1-700 cSt. Requires SA1021 Standard Accessories Kit.
800-00137	MiniVisc 3000 Portable Viscometer, 10-350 cSt. Requires SA1002 Standard Accessories Kit.
800-00141	FluidScan 1100 Lubricant Condition Monitor & MiniVisc 3050 Combo Kit. Requires SA1022 Standard Accessories for Combo Kit.
800-00139	FluidScan 1000 Lubricant Condition Monitor & MiniVisc 3050 Combo Kit. Requires SA1022 Standard Accessories for Combo Kit.

PRODUCT INFORMATION	
Applications	Lubricant oils (mineral and synthetic), coolants, glycol, and any Newtonian fluid within the measuring range
Output	Kinematic viscosity (cSt) @ 40°C V100 viscosity calculation from VI index input (3050 only)
Methodology	ASTM D 8092
Standard Analytical Range	3000: 10-350 cSt @ 40°C 3050: 1-700 cSt @ 40°C
Accuracy	3000: ≤ ± 3% of measured value over range 10-350 cSt 3050: ≤ ± 3% of measured value over range 1-350 cSt ≤ ± 5% of measured value for viscosity > 350 cSt <i>Accuracy specification is with use of user correction function.</i>
Repeatability	3000: ≤ ± 3% RSD of measured value, typical 3050: ≤ ± 3% RSD of value, typical, over range 1-350 cSt ≤ ± 5% RSD of measured value for viscosity > 350 cSt <i>RSD is Relative Standard Deviation.</i>
Test Temperature Control	± 0.1°C
Calibration	Not required

OPERATIONAL SPECIFICATIONS	
Sample Volume	60 µL
Solvents/Reagents	None
Ambient Operating Temperature	0°C to 40°C (32°F to 104°F)
Relative Humidity	10% to 80% r.h. non-condensing
Ambient Altitude	Up to 5,000 meters (16,404 feet)

USER INTERFACE SPECIFICATIONS	
Display	Fixed angle color touchscreen display
Data Transfer	USB for software updates
Data Entry	Touchscreen

POWER REQUIREMENTS	
Battery Power Source	Built in rechargeable lithium ion battery
Power	AC 110/240 V, 50/60 Hz, 10 Watts
Typical Runtime	6-8 hours with full charge
Recharge Time	2.5 hrs

MECHANICAL SPECIFICATIONS	
Dimensions	152 mm (H) x 127 mm (W) x 203 mm (D) (6.0 in x 5.0 in x 8.0 in)
Weight	1.8 kg (4.0 lbs)
Shipping Package Dimensions	50.8 cm (H) x 40.6 cm (W) x 35.6 cm (L) (20 in x 16 in x 14 in)
Shipping Package Weight	4.9 kg (11 lbs)

COMPLIANCE	
CE Mark: EMC Directive (2004/108/EC); RoHS	

CONSUMABLES	
P-11177	Positive displacement pipette, 10-100 µL
P-11178	Pipette tips for P-11177, package of 192
P-11201	Pipette tips for P-11177, package of 960
PV1011	Disposable non-abrasive cleaning pads, package of 500
P-11052	60 µL disposable pipettes, package of 500
PV1025	Visc 30 standard, 20 ml
PV1026	Visc 120 standard, 20 ml

