

A New Era Begins.

B127G

Bandsaw Blade Grinding Machine

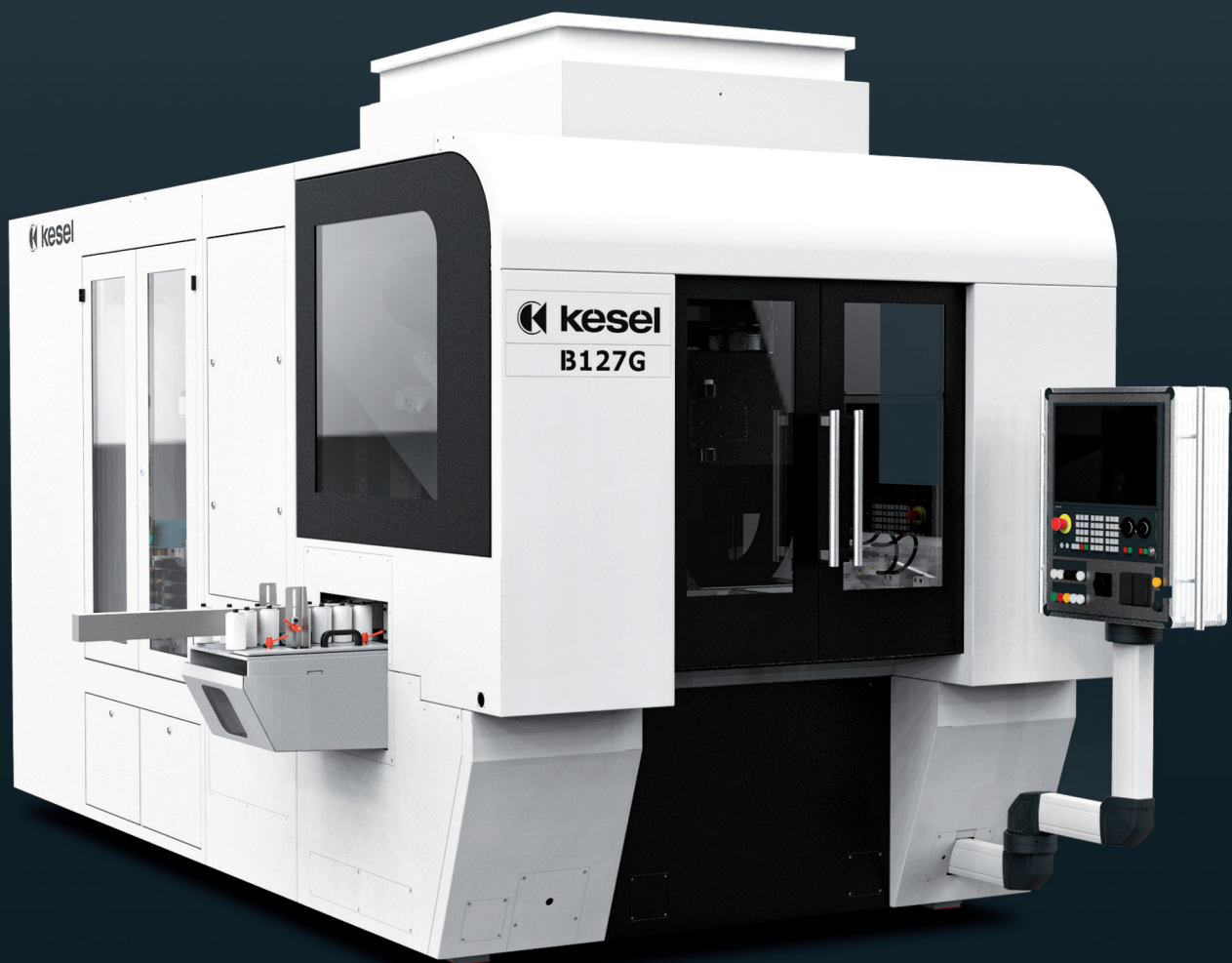

- ▶ Bandsaw Blade Production
- > Steering Rack Production
- > Gear Rack Production
- > Clamping Tools

B127G

Powerful. Innovative. A machine like no other. The B127G embodies the spirit of Kesel, offering speed, precision and productivity with the incredible power of the industry-first S98 grinding head. With the B127G Bandsaw Blade Grinding Machine, we have redefined the experience and the possibilities within the bandsaw grinding world.

Developed to push your grinding experience to the limit. The B127G's modern and digitally enabled SINUMERIK ONE operating platform creates a seamless and ground-breaking interface between man and machine, enabling never seen before results. At the heart of the machine is the powerhouse, S98 grinding head allowing the B127G to cope with huge band packets and the toughest tooth profiles. Flexibility and utility is further boosted with the optional GP2, twin axes dressing unit.

Designed to be easy to operate whilst delivering maximum output, the B127G allows you to harness the full performance that our engineering team have created. A new era begins. Join us in sculpting the future.

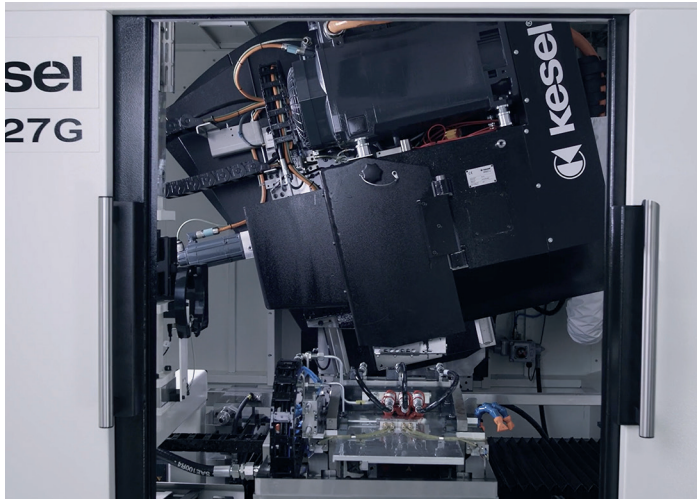

Grinding

The S98 grinding head delivers maximum power across the full 127 mm maximum width of the grinding surface. With an integrated and automatic balancing unit the S98 is not only hugely powerful but maintains absolute precision at all times. The new compact design has been engineered to minimise maintenance requirements whilst increasing positioning accuracy.

The air-cooled dressing spindle on the S98 achieves a reduced energy consumption during dressing whilst maintaining its market-leading precision. With grinding wheels up to a maximum width of 127 mm and 400 mm in diameter, the B127G delivers high-productivity whilst maximising the wheel's usable diameter.



Band feeding and transportation

The band feed system of the B127G has been updated significantly to increase speed of use and dramatically reduce material wastage. Re-designed roller guides and a pneumatic band packet holder ensure band changeovers are completed quickly and effectively.

The zero-loss feed system, a standard feature of the B127G, ensures that grinding begins from the very first millimetre of band material. For organisations conscious of their carbon footprint, the B127G goes a long way to supporting more responsible manufacturing.

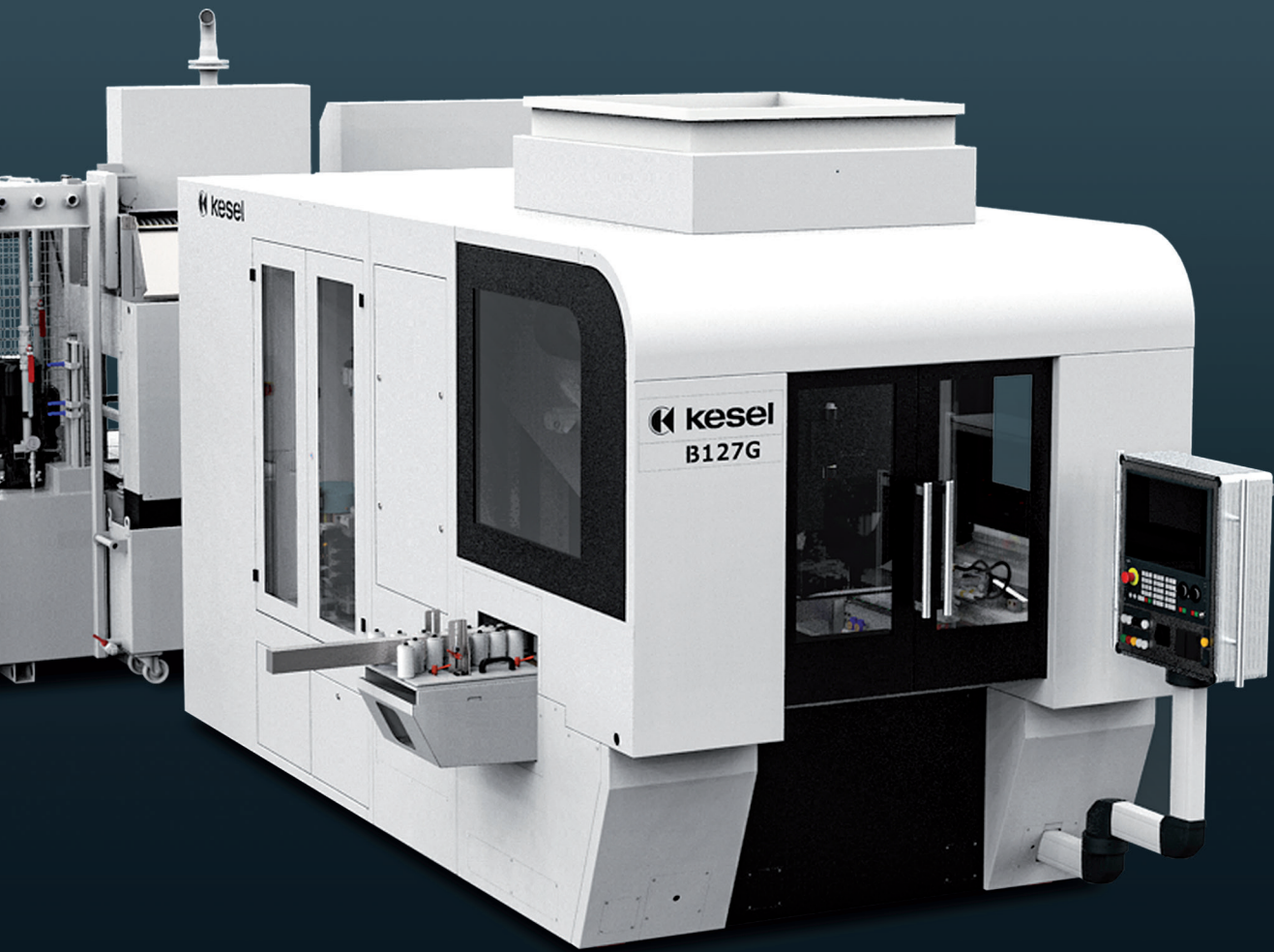

Dressing

Total flexibility and precision. Our standard single axis-dressing unit allows split-second wheel profiling with total control over all the critical performance parameters. Alternatively, the GP2 system allows single and 2-axes dressing, providing an invaluable, additional capability.



Control

The B127G runs on the SINUMERIK ONE system from Siemens, a multicore architecture comprising of state-of-the-art microprocessors. The result? Maximum speed combined with fluid CNC operation, even in high-load scenarios. Implementation of the SIMATIC S7-1500 PLC reduces non-productive times at the machine and offers the best conditions for integrating the B127G into higher-level automated systems.

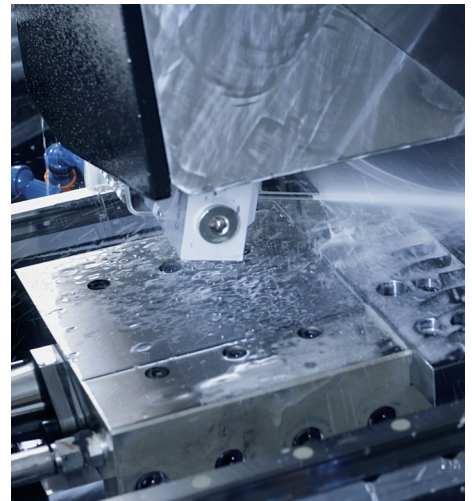

Coolant & Filtration Management

The intelligent coolant management system supplied with the B127G is fully automated to increase operation efficiency. Coolant volumes and pressures are continually monitored and maintained via the coolant unit's control system which is fully integrated into the grinding machine's operating architecture. More complex coolant applications, such as volume and pressure changes during roughing and finish grinding can be easily programmed.

Specification B127G

Travel Range		
X1-axis (horizontal, band feed)	550 mm	
Y1-axis (vertical, tooth height)	225 mm	
Z1-axis (horizontal, feed rate)	465 mm	
C-axis (rotation, rake angle)	swivel range +2 up to -20°	
LD axis (horizontal, levelling device drive)	395 mm	
Travel range - dressing unit		
X32-axis (horizontal)	140 mm	
Y32-axis (vertical)	105 mm	
Travel range coolant tracking		
Y33 axis	110 mm	
Grinding head		
Type	S98	
Power	98 kW S1	
Grinding wheel adapter	Ø 152,4 mm / 6"	
Grinding wheel diameter min.	270 mm	
Grinding wheel diameter max.	400 mm	
Grinding wheel width max.	127 mm	
Control		
Siemens SINUMERIK ONE		
Clamping system		
Clamping width	max. 60 mm	
Possible band width	max. 125 mm	
Jaw width	300 mm	
Coolant and swarf removal		
Cooling lubricant	Emulsion	Grinding oil (optional)
Filling capacity	6,500 Litre	7,800 Litre
Fine filtration	Band filter fleece	Band filter fleece
Integrated coolant monitor and management system		
Electrical connection		
Machine		
Voltage	3 x 400 V	
Nominal current	200 A	
Coolant unit		
Voltage	3 x 400 V	
Nominal current	130 A	
Dimensions and weight		
Installation dimensions:	approx. L: 4,700 x D: 8,600 x H: 3,200 mm	
Machine weight:	approx. 18,000 kg	
Options		
<ul style="list-style-type: none"> - 2-axis dressing unit - Grinding wheel / dresser changing unit - Additional grinding accessories: grinding wheels and associated grinding wheel flanges - Additional clamping accessories: Clamping jaws and band support plates - Oil grinding package - Different coiling system possibilities 		

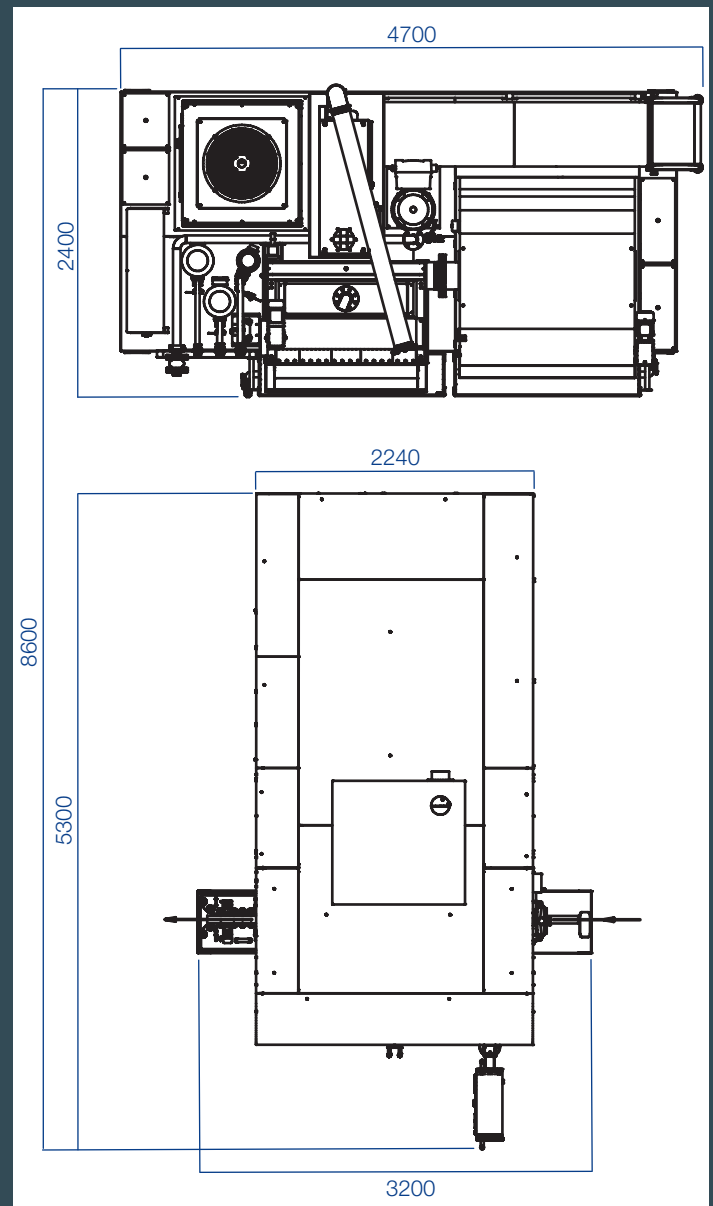

approx. dimensions

Additional accessories available upon request
Subject to modifications arising from technical advances