

# Liebert® NXC™

10 to 40kVA

Compact and Reliable Power in a Fully Integrated Packaged Solution





Regardless of your size, you can't afford for your critical business systems to go down and you can't waste time recovering your IT infrastructure after a disruption.

**Emerson Network Power**, a division of Emerson, is a global company that combines technology with design to supply innovative solutions for the benefit of its customers. Emerson Network Power is the leader in the **"business-critical continuity"** field, thanks to the company's products and services. Emerson Network Power's broad technology base and global expertise support a full spectrum of enterprise-wide solutions for today's vital business needs.

Leave that to us, the experts in business-critical continuity; from grid to chip, from the biggest to the smallest data centers, we are ready to serve your needs with the solutions we have developed.

### Liebert NXC™ delivers Efficiency Without Compromise™

**Efficiency Without Compromise™** provides a path to optimise data center infrastructure around design, operating and management efficiencies - while maintaining or improving availability. This is achieved through the proper selection and utilisation of cooling, power and monitoring technologies, supported by key services and local expertise.



**INFRASTRUCTURE MANAGEMENT**  
Improving performance of the IT infrastructure and environment



**HIGH DENSITY**  
Delivering architectures from 10-60kW/Rack to minimise space and costs



**ECO AVAILABILITY**  
Balancing high levels of availability and efficiency.



**FLEX CAPACITY**  
Adapting to IT changes for continuous optimisation and design flexibility.

# Liebert® NXC™ 10-40 kVA



## Features and Performances

- 0.9 output power factor
- Double conversion efficiency over 94%
- Integrated battery compartment capable of up to 60 mins. of integrated autonomy
- Easy site installation and configuration
- Ecomode efficiency up to 98%
- Active input power factor correction (PFC)
- Input current total harmonic distortion correction (THDi) < 5%
- High capacity battery charger
  - ◆ 10-20kVA ~ 4.5kW
  - ◆ 30-40kVA ~ 6kW
- Input/output and bypass circuit breakers
- Integrated manual bypass
- Integrated parallel load bus and synchronization port (LBS)

## Compact, Reliable Power

Liebert® NXC™ offers reliable and flexible secure power in a fully integrated package solution. It comes complete with highly efficient transformer-free double conversion technology allowing it to provide installation and operating cost savings.

With a rated output power factor of 0.9, the Liebert® NXC™ is also able to provide 11% more active power than a traditional 10-40 kVA UPS. Liebert® NXC™'s combination of performance

features, impressive integrated autonomy and compact footprint make it ideal for guaranteeing clean, continuous power for a wide range of applications from IT, medical facilities and laboratories, office facilities, and retail brands.

Liebert® NXC™ achieves up to 94.5% efficiency in double conversion mode and up to 98% in Eco mode ensuring effective load protection while reducing the total cost of ownership (TCO) and environmental impact.

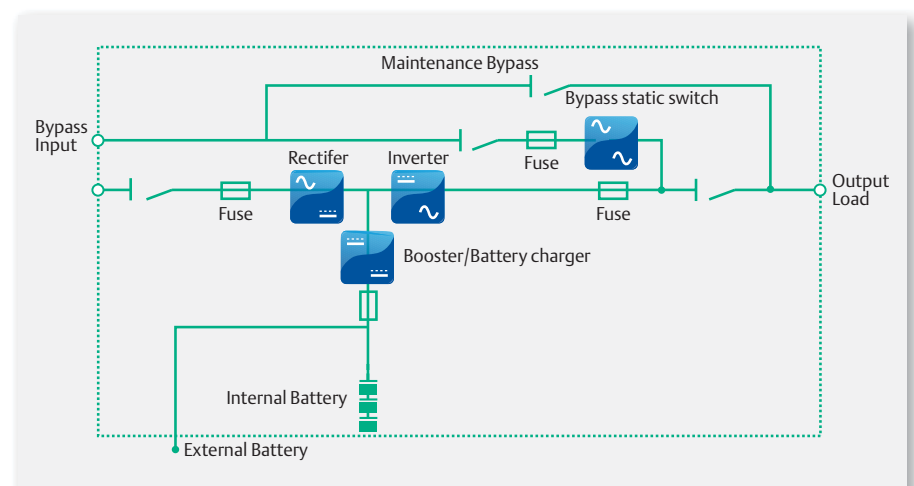

Liebert® NX single-line diagram



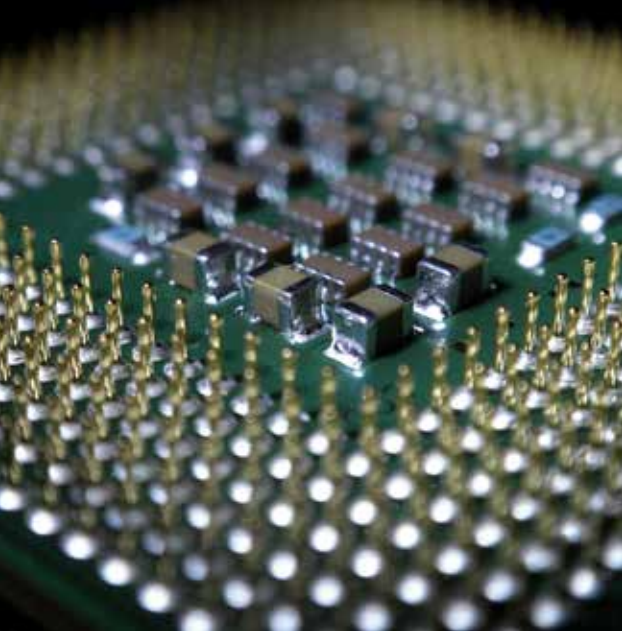

## Flexibility

Liebert<sup>®</sup> NXC<sup>™</sup> is a compact solution designed to optimise installation space requirements and provide enhanced flexibility to ensure superior protection for all load types (leading and lagging).

The internal battery component allows customised configuration options for greater flexibility. It is capable of having different number of battery strings resulting into longer and higher backup time. \*

Liebert<sup>®</sup> NXC<sup>™</sup>'s flexibility is further enhanced through:

- **Built-in transformer option\***
- **Common or distributed battery bank**
- **Reduced footprint**

### Output Configuration

Liebert<sup>®</sup> NXC<sup>™</sup> can be configured on-site to deliver three (3/3) phase output giving it the flexibility to adapt to changes in installation environments.



*\*Consult Emerson representative for configuration.*



## In The Field

### Integrated autonomy

Liebert® NXC™ provides an excellent integrated autonomy which results in back up times of up to one hour.

The batteries housed inside the UPS cabinet which are responsible for delivering Liebert® NXC™'s integrated autonomy have the added advantage of virtually eliminating the need for an external battery cabinet, further reducing installation costs and minimising the demand on physical space.

The powerful 6 kW battery charger of the Liebert® NXC™ allows the reduction of battery re-charging time and increases its ability to manage longer back up times.

### Parallel Ready

Liebert® NXC™ can be connected with up to four units in parallel, one of which is redundant. A single unit can be upgraded to parallel operation via easy to modify software settings which allow the system to be customised for the requested configuration.

The Loop BUS connection used in paralleling the system delivers ultimate reliability and eliminates the possibility of a single point of failure, ensuring perfect load sharing and fast detection of any variation in the system status.



# Communication

Liebert® NXC™ features a multi-lingual LCD user interface allowing close control and monitoring of system status and performance.



The UPS offers the following communication features:

- Voltage-free contact ports
- USB interface
- Internal Intellislot for SNMP or Modbus communication

These communication capabilities make Liebert® NXC™ compatible with any building management system.

## Software Connectivity



**Liebert® Multilink™** software prevents unexpected server shutdowns and minimises downtime warning of pending power losses and initiating safe shutdown of operating systems if required.



**Liebert® Nform™** network communications system enables customers to leverage the distributed monitoring capabilities of network connected equipment providing centralised management of distributed systems.



## Serviceability

The architecture of the Liebert® NXC™ is designed to optimise installation and simplify service with its easily removable power assembly. This architecture considerably minimises the time needed for repairs and optimises serviceability.



Liebert® NXC™ also comes equipped with casters to facilitate ease of movement and relocation.



Emerson Network Power Services has the ability to service your equipment, wherever and whenever it's needed. We maintain the 'health' of your data center as well as optimise your existing network infrastructure by helping you implement best practices that can cut down its energy consumption.

Whenever, wherever and for whatever reason, if you need answers or assistance, we will be ready to make sure your system is up and running. We have more than 300 direct service engineers in Asia, with only "One-Call" you have the solution for all critical services.



#### **Installation and Startup Services**

Emerson Network Power guarantees that your equipment will be up and running immediately once delivered to your doorstep. We give you confidence that your equipment is at optimum performance.



#### **Standard Warranty Service**

Emerson Network Power always makes it a point to only deliver reliable products in the marketplace. Nevertheless, Emerson guarantees one year standard warranty support coverage on each product sold to you.



#### **Extended Warranty Service**

Peace of mind provided by Emerson Network Power certified service and support experts. With our Extended Warranty Service package, count on us and consider it solved. Risk Free, low cost and better ROI.



#### **Power Assurance Package**

The Power Assurance Package bundles a number of key service elements with a Liebert GXT 4.5/6/10kVA UPS. It combines the best UPS in the business with the industry's premier service capability to offer you convenience, information and increased uptime for five full years.



#### **Data Center Audit**

The Data Center Audit Program is a half-day audit of your data center, during which an Emerson expert in data center design and operations compares your infrastructure against more than 50 industry best practices, and identifies your overall risks and capacity challenges.



#### **Data Center Environment Assessment**

Data centers continue to dynamically grow both in number and size. This growth rate is spurred by the increasing number of powerful servers installed in data centers and the demands of supporting equipment such as cooling and power.



#### **Preventive Maintenance Service**

Emerson Network Power's preventive maintenance program helps you maximise the reliability and performance of your power systems and provides you total peace-of-mind. Emerson's trained and certified technicians will implement this service through use of proper tools and genuine parts to ensure longer system reliability.



#### **Remote Monitoring Service**

Capture critical systems data and turn it into action with the remote monitoring service from Emerson. A proven reliable means to know the health and status of your critical infrastructure from alarm notification to custom escalation plans and proactive diagnosis.



## Liebert® NXC™ Specifications

Technical Characteristics				
Ratings (kVA)	10	20	30	40
Output active power at 40° C (kW)	9	18	27	36
Output power factor	0.9			
Parallel configuration	3+1		4+0	
Input				
Input voltage range (possible to reach 100%)	229V-477V	305V-477V	266V-477V	305V-477V
Bypass voltage tolerance (%)	Selectable within -40% to +20%			
Input frequency tolerance (Hz)	40 - 70			
Input power factor	0.99			
Input Total Harmonic Distortion	<5%			
Output				
Nominal output voltage - three phase (V)	380/400/415			
Nominal output frequency (Hz)	50 / 60			
Frequency synch. range (Hz)	2 Hz (selectable 0.5 - 3 Hz)			
Frequency track rate (Hz)	1 Hz			
Inverter overload capacity (%)	105% continuous; 125% 5min ; 150% 1 min			
Double conversion efficiency (%)	up to 94.5%			
Eco mode efficiency (%)	up to 98%			
General				
Noise at 1 m (dBA)	<56	<58	<56	<58
Protection level	IP20			
Frame color	BLACK ZP 7021			
Display	Graphic multi-lingual LCD			
Dimensions And Weight				
Height (mm)	1240		1600	
Width (mm)	500		600	
Depth (mm)	860		850	
UPS weight (kg)	115		215	

### Autonomy time (in mins.)\*

Internal Battery Configuration	10kVA	20kVA
1 x 32 x 9AH	8	n/a
2 x 32 x 9AH	23	8
3 x 32 x 9AH	42	15
4 x 32 x 9AH	57	23
Internal Battery Configuration	30kVA	40kVA
1 x 38 x 34AH	15	10

\*Notes:

1. Longer back-up time is available. Please consult Emerson representative for proper configuration.
2. Autonomy time is based on 100% load and 0.9 UPS Output Power Factor.
3. Condition applies.

### Emerson Network Power Asia

#### Australia

T: 1800-065345  
F: 61-2-97438737

#### Pakistan

T: 92-42-36622526 to 28  
F: 92-42-36622530

#### Japan

T: 81-3-54038594  
F: 81-3-54032924

#### Philippines

T: 63-2-7207400  
F: 63-2-6203693

#### Korea

T: 82-2-34831500  
F: 82-2-5927886

#### Singapore

T: 65-64672211  
F: 65-64670130

#### Malaysia

T: 603-78845000  
F: 603-78845188

#### Thailand

T: 66-2-6178260  
F: 66-2-6178277 to 78

#### New Zealand

T: 64-3-3392060  
F: 64-3-3392063

#### Vietnam

T: 84-4-37628908  
F: 84-4-37628909

### Exclusive Distributor for Indonesia



#### PT DKSH INDONESIA

T: 62-21-3192-4289  
F: 62-21-3192-4290  
www.dksh.com

Marketing.AP@emerson.com  
www.EmersonNetworkPower.Asia

While every precaution has been taken to ensure accuracy and completeness herein, Emerson Network Power assumes no responsibility, and disclaims all liability, for damages resulting from use of this information or for any errors or omissions. Specifications are subject to change without notice. Emerson Network Power and Liebert® are trademarks of Emerson Electric Co. or one of its affiliated companies. All other names and logos referred to are trade names, trademarks, or registered trademarks of their respective owners.

©2015 Emerson Electric Co. AP15DPG-NXCv7-BR

EMERSON. CONSIDER IT SOLVED.™