

STA-10iL

Automated Plasma System

The STA-10iL automated plasma system is designed to clean and activate substrates for improved adhesion. It is ideal for semiconductor packaging and electronics manufacturing. The STA-10iL comes standard with in-line conveyance for high-volume manufacturing. An optional drawer can be installed for high-mix, low-volume production.

Inside the STA-10iL, a three-axis gantry selectively applies the most advanced atmospheric plasma to your substrates. Surfx's Atomflo™ controller operates with low voltage, radio frequency (RF) power, and generates a uniform, particle free, and electrically neutral plasma that is safe on the most sensitive electronics.

The STA-10iL has many options for in-line or batch manufacturing with full traceability:

- Oxygen plasma for organic clean
- Hydrogen plasma for metal oxide removal
- Cleanroom class 100 (1,000 is standard)
- Inert gas purge for reducing gas chemistry
- Substrate Heating and cooling

For more information, contact Surfx at:
sales@surfxtechnologies.com or +1 310 558 0770.

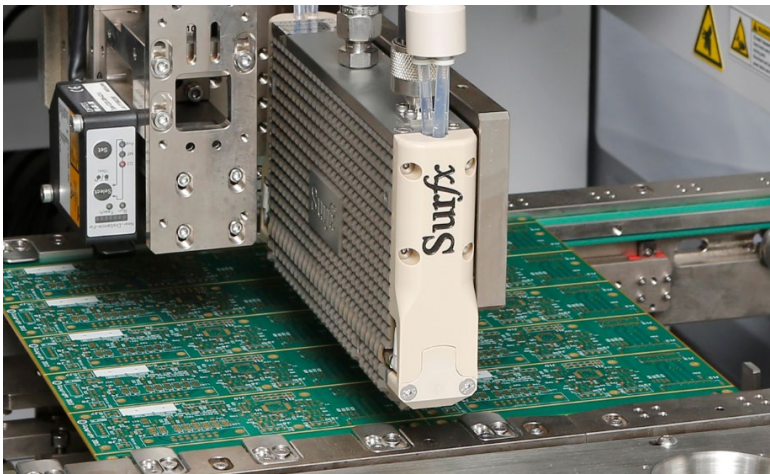

STA-10iL Specifications

Work area (X * Y * Z)

550 x 760 x 60 mm

Footprint (W * D * H)

1,000 x 1,500 x 1,550 mm

39.4 x 59.1 x 61.0 inches

Software and OS

Cloudbreak™ for rapid program development.

Patented plasma technology

Atmospheric argon plasma

O₂, H₂, N₂ plasma chemistry

RF capacitive discharge

www.surfxtechnologies.com

North America

Surfx Technologies, LLC
Los Angeles, CA, USA
Ph: +1 (310) 558-0770
sales@surfxtechnologies.com

Asia

Surfx Technologies Taiwan Co. Ltd.
Taichung City, Taiwan
Ph: +886 4 2263 8200
salesasia@surfxtechnologies.com

STA-10iL

The STA-10iL is designed specifically for precision plasma cleaning of semiconductors and electronics with zero damage, high reliability and single-part traceability.

Specifications	
Power supply	200~240 VAC, 31 A, 50/60 Hz
Air supply (CDA)	0.4-0.6 MPa (60-90 psig), <280 LPM (<10 CFM)
Footprint (W*D*H)	1,000 x 1,500 x 1,550 mm (39.4 x 59.1 x 61.0 inches)
Weight	1,050 kg (2,315 lbs)
Exhaust (flange, factory flow required)	100mm (4inch), 500 CMH (300 CFM)
Motion system	
Work area (X * Y * Z)	550 x 760 x 60 mm
X Y Z repeatability	XY: +/- 0.025 mm @ 3 sigma, Z: +/- 0.005 mm @ 3 sigma
Max speed	1,000 mm/s (X, Y)
Acceleration	1.0 g
Drive system	AC servo & precision ground ball screw
Machine specifications	
Conveyor type and payload	Belt, 3 kg (6.6 lbs)
Trafficking communication	SMEMA
Software and OS	Cloudbreak™ operating on Windows 10
Max top and bottom side clearance	25 mm (1.0 inch)
Atomflo™ plasma specifications	
RF Power	600 W at 27.12 MHz
Main plasma gas	Argon (Ar)
Process gases	Oxygen (O ₂), nitrogen (N ₂), or hydrogen (5.0% H ₂ in Ar)
Process specifications	
Nominal contact angle after plasma	WCA < 10° (native oxide on silicon wafer)
Plasma cleaning process	O ₂ + Ar to remove organics, or H ₂ + Ar to remove metal oxidation

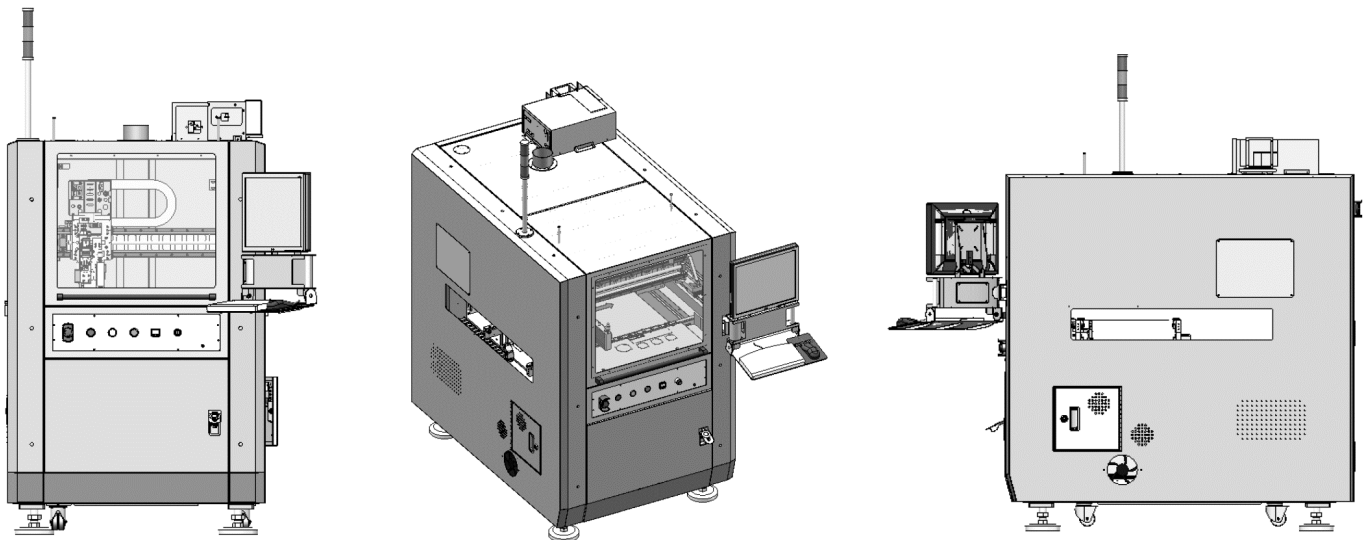

www.surfxtechnologies.com

North America

Surfx Technologies, LLC
 Los Angeles, CA, USA
 Ph: +1 (310) 558-0770
sales@surfxtechnologies.com

Asia

Surfx Technologies Taiwan Co. Ltd.
 Taichung City, Taiwan
 Ph: +886 4 2263 8200
salesasia@surfxtechnologies.com