

# Sartoflow<sup>®</sup> Expert SU

Single-Use TFF System  
Configurable for  
ADC Synthesis

## Executive Summary

Sartoflow<sup>®</sup> Expert SU is a fully automated tangential flow filtration (TFF) system with a closed single-use loop for process development (PD) up to pilot scale. In addition to state-of-the-art TFF, it can be configured to optimize antibody-drug conjugate (ADC) manufacturing at a 1–20 L scale.

Currently, ADC synthesis, precipitate removal, and subsequent TFF occur within separate unit operations. Time consuming and risky transfer steps are necessary between process steps. The Sartoflow<sup>®</sup> Expert SU is the first fully automated single-use system to streamline these three steps, simplifying ADC processing while providing safety for both the operator and product.

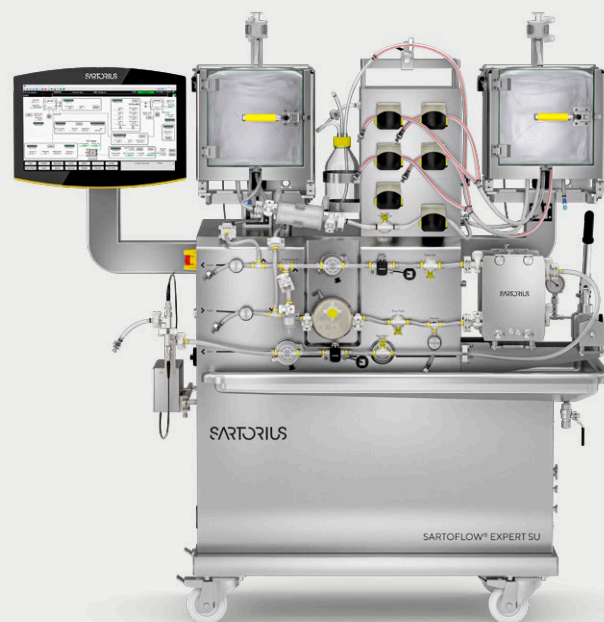

## Unique Selling Points

- Single-use dedicated to 1–20 L scale
- Cost-efficient single-use TFF, from PD to pilot
- Ready-to-use closed-loop system for bioburden-reduced processes

### Optimized for ADC Manufacturing:

- Three unit operations in one fully automated single-use solution
- Save money, labor, and floor space while cutting process risks
- Seamless transition from PD up to low-volume commercial ADC production
- Flexible process sequencing accommodates varied ADC strategies

## Relevant Applications

- Antibody-drug conjugates (ADC)
- Monoclonal antibodies (mAbs)
- Vaccines
- mRNA
- pDNA
- Recombinant proteins
- Biosimilars
- Viral vectors for gene therapy
- High viscosity injectables

## Relevant Process Steps

### ADC & Bioconjugate Applications Steps

- mAb preparation | dilution
- Activation
- Conjugation reaction
- Quenching
- pH adjustment
- Aggregate removal filtration
- UF | DF

### Single-Use TFF Applications –

#### Optimized for High Viscous Applications

- Daily single-use UF | DF work | application
- Optimized mixing (ideal for low volume mixing) under temperature control
- Sampling for advanced analytics

## Technical Specifications

### System

Sartoflow® Expert SU is a modular single-use system offering numerous standard and optional features. The TFF Base Unit for UF and DF applications can be extended with additional modules and consumables. The extensions are added to the TFF Base Unit and do not limit any UF | DF capabilities.



TFF Base Unit configuration with installed flow kits and cassette

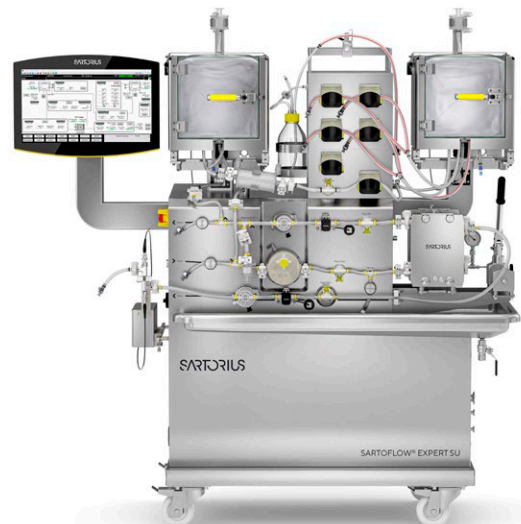

Extended configuration with attached display, installed flow kits, and cassette

	Specification	In TFF Base Unit	In Extension Module
Process Steps		<ul style="list-style-type: none"> <li>▪ Concentration (ultrafiltration)</li> <li>▪ Buffer exchange (diafiltration)</li> <li>▪ Optional - sterile grade filtration</li> </ul>	<ul style="list-style-type: none"> <li>▪ 2<sup>nd</sup> mixer (bioconjugation)</li> </ul>
Membrane Area (flat sheet SU TFF cassettes)	0.14, 0.28, 0.42, 1.4 m <sup>2</sup>	■	■
Typical Batch Size	Depending on application	E.g. up to 500 g mAb	E.g. up to 200 g ADC
Process Volume	Up to 20 L	■	■
Bag Holder	Double jacketed holder for 3D single-use mixing bag (20 L) with bottom impeller, sampling port, and conical bottom for complete draining	1× for recirculation incl. conductivity measurement	+1× for 2 <sup>nd</sup> mixer incl. pH measurement
Loop Volume (feed, retentate, pump head)	~400 mL	■	■
Minimum Recirculation Volume (loop volume & min. filling level of bag)	~600 mL	■	■
Recirculation Pump	5-piston single-use diaphragm pump with integrated overpressure protection at 4 bar (pump capacity 900 L/h)	■	■
Media Addition Pumps	Watson-Marlow DriveSure 313 VBM/D peristaltic pump (1,500 mL/min)	2 (+4× optional)	6
Temperature Control Unit (TCU)	Operating range: 10 - 40°C (at <0.5 bar)	□	■
Sterilizing-grade Filtration Module	0.2 µm	□	■
Process Controls	Pressure (TMP, inlet, outlet, delta pressure)	■	■
	Flow (retentate)	■	■
	Temperature (bags)	■	■
	Level control (bag holder)	■	■
	External balances (media addition)	■	■
Process Analytics	UV (permeate)	□	□
	Conductivity (recirculation bag)	■	■
	pH (2 <sup>nd</sup> mixing bag)	-	■
	Flow (permeate, retentate, feed)	■	■
	Pressure (TMP, inlet, outlet, delta pressure)	■	■
	Weight (bagholders)	■	■
System Operation	<ul style="list-style-type: none"> <li>▪ Fully automated</li> <li>▪ Based on PLC S7 1500, ET200 SP</li> </ul>	■	■
Dimensions (W × H × D)	Attached 22" display	1,430 × 1,755 × 755 mm	1,875 × 1,755 × 755 mm
	Detached 22" display	-	1,400 × 1,755 × 755 mm
Weight of Empty System	~450 kg	■	■
Power Supply	<ul style="list-style-type: none"> <li>▪ 100 - 120 V, 50/60 Hz, 9A</li> <li>▪ 220 - 240 V, 50/60 Hz, 5A</li> </ul>	■	■
Utility Requirements	<ul style="list-style-type: none"> <li>▪ Cool water supply</li> <li>▪ Cool water return</li> <li>▪ Safety valve drain</li> <li>▪ Compressed air supply (6 bar   90 psi)</li> </ul>	■	■
cGMP Compliant	Documentation   Testing	On request	On request

■ (included) □ (optional) - (not available)



## Single-Use Mixing Bags

The Flexsafe® single-use 3D mixing bags allow efficient mixing and temperature control in 1-20 L scale. With an integrated sampling port and sensors (conductivity or pH), quality can be monitored at all times. In addition, the conical shape of the bags and bag holder enable maximum drainage for highest yields. All materials in product contact are resistant to organic solvents.

- ✓ Efficient mixing in low volumes
- ✓ Precise temperature control
- ✓ Easy quality controls
- ✓ High yield
- ✓ Chemical compatibility



Flexsafe® Recirculation bag



Flexsafe® 2<sup>nd</sup> mixing bag

	Specification	Recirculation	2 <sup>nd</sup> Mixing Bag
Order No.		FMS310600	FMS310569
Capacity	20 L	■	■
Lines on Bag: Tube Type   Diameter ID×OD   Connections		<ul style="list-style-type: none"> <li>▪ Feed: Tuflux® Silicone (Pt) ½" × ¾"   Aseptiquik®-G HT</li> <li>▪ Retentate: Tuflux® Reinforced silicon (Pt) ⅜" × ⅝"   Aseptiquik®-G HT</li> <li>▪ Filtration: Tuflux® Silicone (Pt) ¼" × ⅞"   Aseptiquik®-G HT</li> <li>▪ 2× Buffer: Tuflux® Silicone (Pt) ¼" × ⅞"   MPC female</li> </ul>	<ul style="list-style-type: none"> <li>▪ mAb   buffer: Tuflux® Silicone (Pt) ¼" × ⅞"   2× MPC female</li> <li>▪ mAb: Tuflux® Silicone (Pt) ¼" × ⅞" + (y-connection) 2× Tuflux® TPE ¼" × ⅞"   2× MPC female</li> <li>▪ Quenching: Tuflux® Silicone (Pt) ¼" × ⅞" + (y-connection) 2× Tuflux® TPE ¼" × ⅞"   2× MPC female</li> <li>▪ Payload: Tuflux® TPE ¼" × ⅞"   Luer male</li> <li>▪ Transfer line: Tuflux® Silicone (Pt) ¼" × ⅞"   Aseptiquik®-G</li> <li>▪ Solvent: Tuflux® Silicone (Pt) ¼" × ⅞"   2× MPC female</li> </ul>
Sampling	Tuflux® Silicone (Pt) ¼" × ⅜"   Luer female	■	■
Venting   Bag Tester Connection	Tuflux® Silicone (Pt) ⅜" × ⅝" + Sartopore Air 0.2 µm size 7	■	■
Temperature	Type: PT100 Accuracy: class A (dT = ± (0,15 °C + 0.002 T))	■	■
Conductivity	Type: 4-electrodes conductivity-meter (integrated Pt-1000 sensor) Measurement range: 0.1-200 mS/cm Accuracy: 3% of current value for 0.1-100 mS/cm; 5% of current value for 100-200 mS/cm	■	-
pH	Single-use pH electrode: Measuring principle: electrochemical Measurement range: pH 3-10 Accuracy: pH 0.1 (within ± 1 pH of recalibration pH value)	-	■
Magnetic Impeller	Maximum mixing speed: 1,500 rpm	■	■

## Product Wetted Materials

<b>Single-use Flow Kits</b>	
Polycarbonate (PC)	Sterile connector parts, couplings, sealing plugs
Polyethylene (PE)	Sterile connector parts, air capsule parts
Silicone (Si)	Sterile connector parts, tri-clamp gasket
Polypropylene (PP)	Joining pieces, ferrules, diaphragm valve parts, air capsule parts, tri-clamp gaskets, SU pump head parts
Thermoplastic elastomers (TPE)	Diaphragm valve parts
Polyethersulfon (PES)	Air capsule parts
Polybutylene terephthalate (PBT)	Flow and pressure measurement pipes
Polysulfone (PSU)	Turbidity flow cell
Tuflux® TPE (thermoplastic elastomers)	Tubes
Tuflux® SIL (Pt) (platinum-cured silicone)	Tubes
Sani-Tech® STHT®-R (platinum-cured braid-reinforced silicone)	Tubes
Ethylene propylene diene monomer (EPDM)	SU pump head parts
Santoprene® Thermoplastic Vulcanizates (TPV)	SU pump head parts
Buna	SU pump head parts

<b>Single-use Bags</b>	
Polyethylene (PE)	pH electrode port (in FMS310569 only), conductivity sensor (in FMS310600 only), sealing plugs, bag port flange, ports, mixer bag chamber, conductivity sensor, sterile connector parts, air capsule part
Polycarbonate (PC)	Sterile connector parts, air capsule parts, couplings
Low-density polyethylene (PE-LD)	Mixer parts
Silicone (Si)	Sterile connector parts, air capsule parts, clave connector
Ethylene propylene diene monomer (EPDM)	pH electrode (in FMS310569 only)
High density poly ethylene (HDPE)	pH electrode (in FMS310569 only)
Polypropylene (PP)	pH electrode clamp, air capsule parts, joining pieces, clave connector
Polyethersulfon (PES)	Sterile connector parts, air capsule parts
Acrylic	Clave connector
Polybutylene terephthalate (PBT)	Clave connector
Tuflux® TPE (Thermoplastic elastomers)	Tubes
Tuflux® SIL (Pt) (platinum-cured silicone)	Tubes



# Ordering Information

## Single-Use Flow Kits and Bags

All items must and can be ordered separately. The visually bundled consumables are required to fully equip the system for one application run. Cassettes also have to be ordered separately.

	Description	Order Code
<b>UF   DF Set</b>		
Recirculation Bag	20 L 3D mixing bag with sampling port, conductivity probe	FMS310600
Feed Flow Kit	With pressure sensor	SFE-TUB-FEED
Retentate+ Permeate Flow Kit	<ul style="list-style-type: none"> <li>▪ Retentate with pressure sensor</li> <li>▪ Permeate with pressure, flow sensors, UV measurement</li> </ul>	SFE-TUB-PERM-RET
<b>Optional for UF   DF</b>		
Prefiltration Flow Kit	Flow kit for connection of sterile grade filter (below)	SFE-TUB-PRECIFIL
Prefilter (sterile grade filter)	Sartolon® 0.2 µm (pack of 4)	5105307H9--FF--A
Media Addition Flow Kit	Additional media addition lines	SFE-TUB-MANIFOLD
<b>Consumable Set for Fully Equipped System   ADC (UF   DF, Sterilizing-grade Filtration, 2<sup>nd</sup> Mixing)</b>		
Recirculation Bag	20 L 3D mixing bag with sampling port, conductivity probe	FMS310600
2 <sup>nd</sup> Mixing Bag (only compatible with system configuration with 2 <sup>nd</sup> bag holder on the right)	20 L 3D mixing bag with sampling port, pH probe	FMS310569
Feed Flow Kit	With pressure sensor	SFE-TUB-FEED
Retentate+ Permeate Flow Kit	<ul style="list-style-type: none"> <li>▪ Retentate with pressure sensor</li> <li>▪ Permeate with pressure, flow sensors, UV measurement</li> </ul>	SFE-TUB-PERM-RET
Prefiltration Flow Kit	Flow kit for prefiltration   precipitate removal	SFE-TUB-PRECIFIL
Prefilter (sterile grade filter)	Sartolon® 0.2 µm (pack of 4)	5105307H9--FF--A
Media Addition Flow Kit	Additional media lines	SFE-TUB-MANIFOLD
Mycap®	Mycap® single-use bottle cap, 3 ports, for toxin transfer from 1,000 mL schott glass bottle	MYCAPSSBL0001

## TFF Cassettes

Sartocon® Slice Self-Contained ECO | Sartocube® Self-Contained ECO

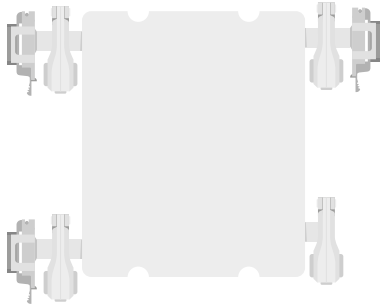

Sartocube® Self-Contained ECO

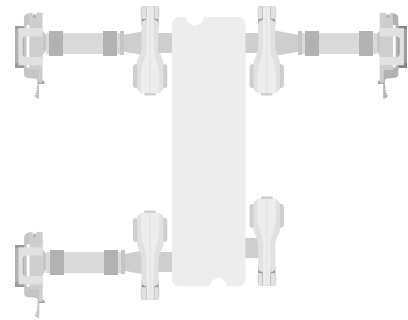

Sartocon® Slice Self-Contained ECO

## Hydrosart® Membrane

Hydrosart® membranes are chemically compatible with organic solvents.

Type	MWCO [kDa]	Filtration Area [m <sup>2</sup> ]	Order Code
Sartocon® Slice SC	10	0.14	SFM-AQ-1443901
Sartocon® Slice SC	10	0.28	SFM-AQ-1443921
Sartocon® Slice SC	10	0.42	SFM-AQ-1443931
Sartocube® SC	10	1.4	SFM-AQ-1443914
Sartocon® Slice SC	30	0.14	SFM-AQ-1445901
Sartocon® Slice SC	30	0.28	SFM-AQ-1445921
Sartocon® Slice SC	30	0.42	SFM-AQ-1445931
Sartocube® SC	30	1.4	SFM-AQ-1445914
Sartocon® Slice SC	100	0.14	SFM-AQ-1446801
Sartocon® Slice SC	100	0.28	SFM-AQ-1446821
Sartocon® Slice SC	100	0.42	SFM-AQ-1446831
Sartocube® SC	100	1.4	SFM-AQ-1446814
Sartocon® Slice SC	300	0.14	SFM-AQ-1447901
Sartocon® Slice SC	300	0.28	SFM-AQ-1447921
Sartocon® Slice SC	300	0.42	SFM-AQ-1447931
Sartocube® SC	300	1.4	SFM-AQ-1447914



## PES Membrane

Type	MWCO [kDa]	Filtration Area [m <sup>2</sup> ]	Order Code
Sartocon® Slice SC	10	0.14	SFM-AQ-1463901
Sartocon® Slice SC	10	0.28	SFM-AQ-1463921
Sartocon® Slice SC	10	0.42	SFM-AQ-1463931
Sartocube® SC	10	1.4	SFM-AQ-1463914
Sartocon® Slice SC	30	0.14	SFM-AQ-1465901
Sartocon® Slice SC	30	0.28	SFM-AQ-1465921
Sartocon® Slice SC	30	0.42	SFM-AQ-1465931
Sartocube® SC	30	1.4	SFM-AQ-1465914
Sartocon® Slice SC	100	0.14	SFM-AQ-1466801
Sartocon® Slice SC	100	0.28	SFM-AQ-1466821
Sartocon® Slice SC	100	0.42	SFM-AQ-1466831
Sartocube® SC	100	1.4	SFM-AQ-1466814
Sartocon® Slice SC	300	0.14	SFM-AQ-1467901
Sartocon® Slice SC	300	0.28	SFM-AQ-1467921
Sartocon® Slice SC	300	0.42	SFM-AQ-1467931
Sartocube® SC	300	1.4	SFM-AQ-1467914

**Germany**

Sartorius Stedim Biotech GmbH  
August-Spindler-Strasse 11  
37079 Goettingen  
Phone +49 551 308 0

**USA**

Sartorius Stedim North America Inc.  
565 Johnson Avenue  
Bohemia, NY 11716  
Toll-Free +1 800 368 7178

 **For more information, visit**  
[www.sartorius.com](http://www.sartorius.com)